

HDP 200 High Pressure Pump Series

Design criteria

Hammelmann high pressure pumps are built to operate at the continuous maximum duty stated in the performance parameters. Just compare the crankshaft speed, average plunger speed, plunger diameter and power rating.

High pressure pump

Weight: approx. 525 kg

Energy efficient →

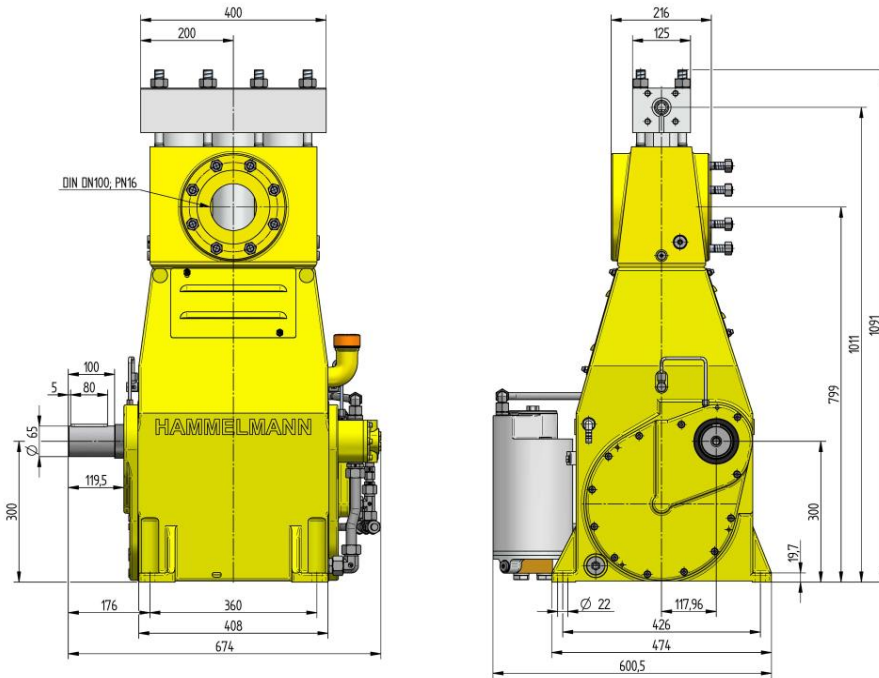

Features

- Power ratings up to 200 kW
- Vertical 3 cylinder design
- Wide variety of complementary ancillaries

Stationary unit with electric motor

Length: 2038 mm
Width: 850 mm
Height: 1380 mm
Weight: approx. 2000 kg at 160 kW

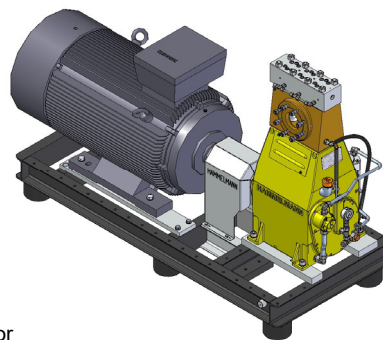

Main dimensions without accessories such as suction line, pressure regulator etc. Detailed dimensional drawings and weights available on request.

Stationary unit with diesel motor

Length: 2560 mm
Width: 1540 mm
Height: 2050 mm
Weight: approx. 3200 kg at 235 kW with full fuel tank

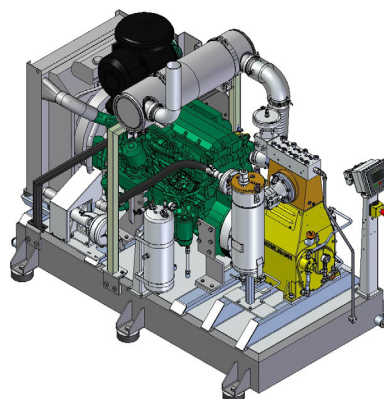

Quality and reliability

- Crank section calculation by 'Finite element method' ensures long working life under continuous load
- Stainless steel pump head free of alternating stress
- Integral speed reduction gear
- Pressurised oil lubrication system with oil cooler/filter
- Bellows form hermetic seal between the suction chamber and crank section
- Solid ceramic or tungsten carbide plungers
- Choice of application specific seal assemblies
- Choice of bronze (standard) or stainless steel suction chamber



+44 1905 751790
sales@calder.co.uk
www.calderltd.com

Calder Ltd
Prescott Drive
Worcester
WR4 9NE
United Kingdom



HDP 200 series, technical data

Performance parameters (Standard design)

Note: Actual flow rates for water as pumped medium (volumetric efficiency has already been taken into account).

HDP	Q [l/min]	Required power rating [kW]						D	r.p.m.	
		75	90	110	132	160	200		n 1	n 2
		Operating pressure [bar]								
204	16/14*	2600*	3100*	3800*	4500*			15	1250/1500	416
	19/17*	2200*	2600*	3200*	3800*	4500*			1500/1800	495
	22/20*	1810	2200*	2700*	3200*	3900*	4500*		1500/1800/2150	593
	21/20*	1900	2300*	2800*	3200*				1250/1500	416
	25/24*	1600	1910	2300*	2800*	3200*		1500/1800	495	
	30/28*	1330	1600	1950	2300*	2800*	3200*	1500/1800/2150	593	
	26/25*	1560	1870	2300*	2800*	3000*		19,3	1250/1500	416
	31/30*	1310	1570	1920	2300*	2800*	3000*		1500/1800	495
	37/36*	1100	1310	1610	1930	2300*	2900*		1500/1800/2150	593
	29/28*	1450	1740	2100*	2600*	2800*		20	1250/1500	416
	34/33*	1220	1470	1800	2200*	2600*	2800*		1500/1800	495
	41/39*	1020	1220	1500	1800	2200*	2700*		1500/1800/2150	593
*Ultra high pressure 3200 bar only for stationary units										
203	44	930	1120	1360	1640	1800		25	1500	416
	52	780	940	1150	1380	1670	1800		1500/1800	495
	62	650	780	960	1150	1400	1740		1500/1800/2150	593
	55	740	900	1100	1310	1430		28	1500	416
	65	620	750	910	1100	1300	1430		1500/1800	495
	78	520	620	760	920	1110	1400		1500/1800/2150	593
202	62	650	780	950	1140	1240		30	1500	416
	73	540	650	800	960	1160	1240		1500/1800	495
	88	450	540	660	800	970	1210		1500/1800/2150	593
	78	530	640	780	940	1030		33	1500	416
	92	450	540	660	800	960	1030		1500/1800	495
	111	370	450	550	660	800	1000		1500/1800/2150	593
	84	470	570	700	840	910		35	1500	416
	100	400	480	600	700	850	910		1500/1800	495
	119	330	400	500	600	710	900		1500/1800/2150	593
	111	360	440	530	640	700		40	1500	416
	132	310	370	450	540	650	700		1500/1800	495
	158	250	310	370	450	540	680		1500/1800/2150	593
	141	300	340	420	510	550		45	1500	416
	168	240	300	350	420	510	550		1500/1800	495
	202	200	240	300	350	430	540		1500/1800/2150	593
	176	230	280	340	410	450		50	1500	416
	210	200	230	300	340	420	450		1500/1800	495
	252	160	200	240	300	350	440		1500/1800/2150	593
	213	200	230	280	340	370		55	1500	416
	254	160	200	240	280	340	370		1500/1800	495
	304	130	160	200	240	300	360		1500/1800/2150	593
	251	160	200	240	280	310		60	1500	416
	299	140	160	200	240	300	310		1500/1800	495
	358	110	140	170	200	240	300		1500/1800/2150	593
298	140	170	200	240	270		65	1500	416	
355	120	140	170	200	250	270		1500/1800	495	
425	100	120	140	170	210	260		1500/1800/2150	593	
342	120	140	170	210	230		70	1500	416	
407	100	120	150	180	210	230		1500/1800	495	
488	80	100	120	150	180	220		1500/1800/2150	593	

- Rod force: 88 kN
- Stroke: 75 mm
- Mean piston speed at n₂
416 r.p.m. = 1,04 m/sec
495 r.p.m. = 1,24 m/sec
593 r.p.m. = 1,48 m/sec

Typical high pressure pump units



- Mobile unit with electric motor



- Road going trailer or stationary units with sound damping cover



- 10 or 20 foot sound damped container versions

Energy efficient →

Hammelmann plunger pumps convert 93 to 98 % of the shaft power to hydraulic energy.

Conversion table
Rating 1 kW = 1.34 HP
Op. pressure 1 bar = 14.5 psi
Flow rate 1 l = 0.264 US gallon
1 l = 0.22 Imp. gallon

D = Piston/Plunger dia. [mm]
n1 = Motor/Engine r.p.m.
n2 = Crankshaft r.p.m.

** The dynamic high pressure sealing extends the advantages of the labyrinth design with further increased efficiency.

*** Special ceramic plungers up to max. 3000 bar.

HDP	Seal **	Sealing system
204	Dynamic	Tungsten carbide plunger & bushing
	Packing	Special ceramic plunger *** / packing
203	Dynamic	Ceramic plunger / bronze bushing
	Packing	Ceramic plunger / packing
202	Dynamic	Ceramic plunger / bronze bushing
	Packing	Ceramik plunger / packing