

HDP 70 High Pressure Pump Series

Design criteria

Hammelmann high pressure pumps are built to operate at the continuous maximum duty stated in the performance parameters. Just compare the crankshaft speed, average plunger speed, plunger diameter and power rating.

High pressure pump

Weight: approx. 215 kg

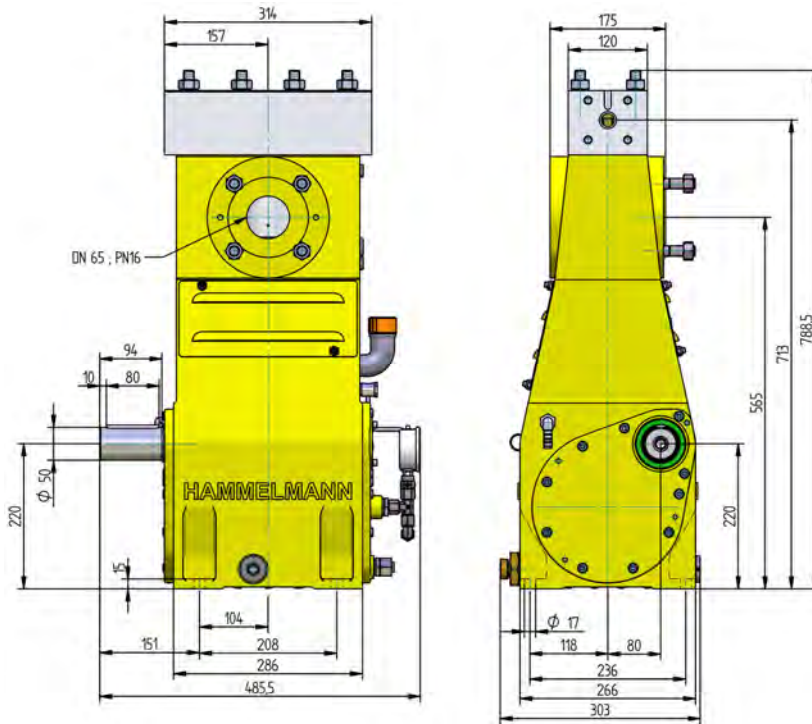

Energy efficient →



Features

- Power ratings up to 70 kW
- Vertical 3 cylinder design
- Wide variety of complementary ancillaries

Quality and reliability

- Stainless steel pump head free of alternating stress
- Bellows form hermetic seal between the suction chamber and crank section
- Choice of application specific seal assemblies
- Solid ceramic or tungsten carbide plungers
- Choice of bronze (standard) or stainless steel suction chamber
- Crank section calculation by 'Finite element method' ensures long working life under continuous load
- Integral speed reduction gear
- Pressurised oil lubrication system with oil cooler/filter

Stationary unit with electric motor

Length: 1502 mm
 Width: 720 mm
 Height: 1105 mm
Weight: approx. 1150 kg at 75 kW

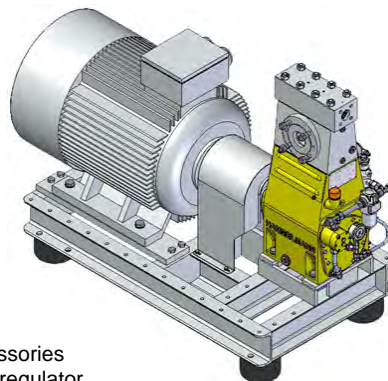

Main dimensions without accessories such as suction line, pressure regulator etc. All shown as right side drive. Detailed dimensional drawings and weights available on request.

HDP 70 series, technical data

Performance parameters (Standard design)

Note: Actual flow rates for water as pumped medium (volumetric efficiency has already been taken into account).

HDP	Q [l/min]	Required power rating [kW]					D	r.p.m.			
		30	37	45	55	70		n 1	n 2		
74	5,9 / 4,9* 7,1 / 5,9* 8,5 / 7,0*	2900* 2400* 2000*	3600* 3000* 2500*	4400* 3600* 3000*	4500* 4400* 3700*	4500*	10	1500	625		
	7,5 / 7,2* 9,0 / 8,7* 11,0 / 10,0*	2000* 1680 1400	2500* 2100* 1730	3000* 2500* 2100*	3700* 3100* 2600*	3800* 3300*		12	1500	625	
	12,0 / 11,0* 14,0 / 14,0* 17,0 / 16,0*	1300 1080 900	1600 1330 1110	1940 1610 1340	2400* 1970 1640	2400* 2100*			15	1500	625
	16 20 24	950 800 660	1170 970 810	1420 1180 1000	1740 1450 1210	1800 1540				17,5	1500

*Ultra high pressure

73	21	730	900	1100	1330	20	1500	625
	26	600	750	910	1110		1370	1500/1800

72	26	600	740	900	1100	22	1500	625	
	31	500	620	750	920		1130	1500/1800	750
	32	500	620	760	920		24	1500	625
	38	420	520	630	770			950	1500/1800
	38	430	530	640	800		26	1500	625
	45	360	440	540	660			810	1500/1800
	50	320	400	480	600		30	1500	625
	60	270	330	400	500			610	1500/1800
	69	240	300	360	430		35	1500	625
	82	200	240	300	360			450	1500/1800
	90	180	220	270	330		40	1500	625
	109	150	200	230	280			340	1500/1800
	113	140	180	220	260		45	1500	625
	136	120	150	180	220			270	1500/1800
140	120	140	170	210	50	1500	625		
168	100	120	150	180		220	1500/1800	750	
169	100	120	140	180	55	1500	625		
203	80	100	120	150		180	1500/1800	750	

HDP	Seal **	Sealing system
74	Dynamic	Tungsten carbide plunger & bushing
	Packing	Special ceramic plunger *** / packing
73	Dynamic	Ceramic plunger / bronze bushing
	Packing	Ceramic plunger / packing
72	Dynamic	Ceramic plunger / bronze bushing
	Packing	Ceramik plunger / packing

** The dynamic high pressure sealing extends the advantages of the labyrinth design with further increased efficiency.

*** Special ceramic plungers up to max. 2600 bar.



Hammelmann plunger pumps convert 93 to 98 % of the shaft power to hydraulic energy.

+44 1905 751790
sales@calder.co.uk
www.calderltd.com

Calder Ltd
Prescott Drive
Worcester
WR4 9NE
United Kingdom

- Rod force: 43 kN
- Stroke: 40 mm
- Mean piston speed at n2
625 r.p.m. = 0,84 m/sec
750 r.p.m. = 1,00 m/sec
900 r.p.m. = 1,20 m/sec

Typical high pressure pump units



- Stationary unit with electric motor



- Trolley

D = Piston/Plunger dia. [mm]
n1 = Motor/Engine r.p.m.
n2 = Crankshaft r.p.m.

Conversion table
Rating 1 kW = 1.34 HP
Op. pressure 1 bar = 14.5 psi
Flow rate 1 l = 0.264 US gallon
1 l = 0.22 Imp. gallon



- Trailer for in plant transport with sound damping cover
- 10 or 20 foot sound damped container versions

HAMMELMANN®