

# High Pressure Pump Series HDP 500

## Design criteria

Hammelmann high pressure pumps are built to operate at the continuous maximum duty stated in the performance parameters. Just compare the crankshaft speed, average plunger speed, plunger diameter and power rating.

### High pressure pump

Weight: 1960 kg

Energy efficient →

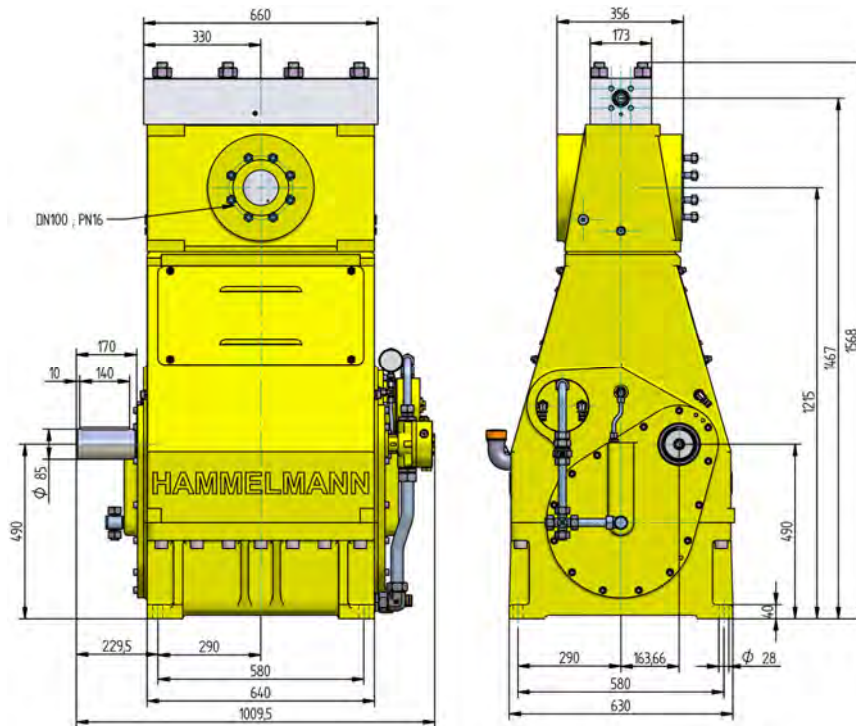

### Features

- Power ratings up to 500 kW
- Vertical 3 cylinder design
- Wide variety of complementary ancillaries

### Quality and reliability

- Stainless steel pump head free of alternating stress
- Cross head piston bellows seal
- Choice of 'application specific' seal assemblies
- Solid ceramic or tungsten carbide plungers
- Choice of bronze or stainless steel suction chamber
- Crank section calculation by 'Finite element method' ensures long working life under continuous load
- Crankshaft supported by 2 bearings and incorporating twin helical speed reducing gears
- Pressurised oil lubrication system with oil cooler/filter

### Stationary unit with electric motor

Length: 2896 mm  
 Width: 1330 mm  
 Height: 1910 mm  
 Weight: approx. 5600 kg at 400 kW

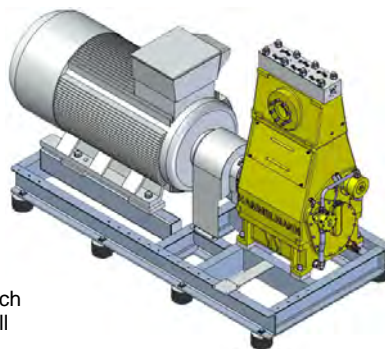

Main dimensions without accessories such as suction line, pressure regulator etc. All shown as right side drive. Detailed dimensional drawings and weights available on request.

### Stationary unit with diesel engine

Length: 3140 mm  
 Width: 1690 mm  
 Height: 2410 mm  
 Weight: approx. 6700 kg at 522 kW with full fuel tank

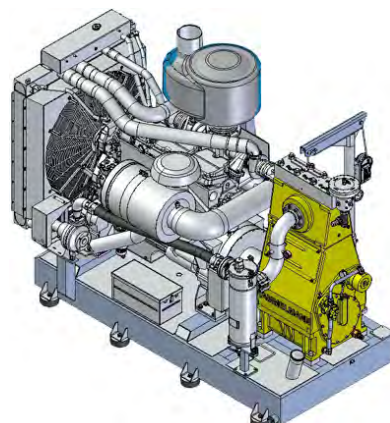

# HDP 500 series, technical data

Performance parameters (Standard design)

HDP	Q [l/min]	Required power rating [kW]					D	r. p. m.	
		300	350	400	450	500		n 1	n 2
		Operating pressure [bar]							
504	52*	2900*	3000*				28	1500	315
	63*	2400*	2800*	3000*		1500/1800		380	
	77*	2000*	2300*	2700*	3000*	1800		465	
	70 / 68*	2300*	2600*				32	1500	315
	84 / 82*	1870	2200*	2500*	2600*	1500/1800		380	
	103 / 100*	1520	1780	2000*	2300*	1800		465	
	85 / 83*	1880	2200*				35	1500	315
	102 / 100*	1560	1820	2100*	2200*	1500/1800		380	
	125 / 122*	1270	1500	1700	1910	1800		465	
*Ultra high pressure									
503	113	1440	1670				40	1500	315
	136	1200	1400	1600	1670	1500/1800		380	
	167	980	1140	1300	1460	1800		465	
502	143	1140	1320				45	1500	315
	172	940	1100	1260	1320	1500/1800		380	
	211	770	900	1030	1160	1800		465	
	178	920	1070				50	1500	315
	215	760	900	1020	1070	1500/1800		380	
	263	620	730	830	940	1800		465	
	213	760	880				55	1500	315
	257	630	740	840	880	1500/1800		380	
	315	520	600	700	770	1800		465	
257	640	740				60	1500	315	
309	530	620	710	740	1500/1800		380		
379	430	510	580	650	1800		465		
304	550	630				65	1500	315	
367	450	530	600	630	1500/1800		380		
449	370	430	500	550	1800		465		
353	470	550				70	1500	315	
426	400	450	520	550	1500/1800		380		
521	320	370	420	480	1800		465		
405	410	480				75	1500	315	
489	340	400	450	480	1500/1800		380		
598	280	320	370	420	1800		465		
447	360	420				80	1500	315	
539	300	350	400	420	1500/1800		380		
659	240	280	330	370	1800		465		
501 High flow	447	360	420				80	1500	315
	539	300	350	400	420	1500/1800		380	
	659	240	280	330	370	1800		465	
	504	320	370				85	1500	315
	608	260	310	350	370	1500/1800		380	
	744	220	250	300	320	1800		465	
	571	280	330				90	1500	315
	689	240	280	310	330	1500/1800		380	
	843	200	220	260	300	1800		465	
	705	230	270				100	1500	315
	851	200	220	250	270	1500/1800		380	
	1041	160	180	210	230	1800		465	
871	200	220				110	1500	315	
1051	160	180	210	220	1500/1800		380		
1286	130	150	170	200	1800		465		

**Note: Actual flow rates for water as pumped medium (volumetric efficiency has already been taken into**

- Rod force: 210 kN
- Stroke: 100 mm
- Mean piston speed at n<sub>2</sub>  
315 r.p.m. = 1,06 m/sec  
380 r.p.m. = 1,27 m/sec  
465 r.p.m. = 1,54 m/sec

Typical high pressure pump units



- Stationary unit with diesel motor



- Stationary unit with electric motor

**Energy efficient** →

Hammelmann plunger pumps convert 93 to 98 % of the shaft power to hydraulic energy.

Conversion table

Rating	1 kW = 1.34 HP
Op. pressure	bar = 14.5 psi
Flow rate	1 l = 0.264 US gallon
	1 l = 0.22 Imp. gallon

HDP	Seal**	Sealing system
504	Dynamic D 28	Tungsten carbide plunger & bushing
	Dynamic D 35	Tungsten carbide plunger / bronze bushing
503	Dynamic	Ceramic plunger / bronze bushing
	Packing	Ceramic plunger / packing
502	Dynamic D 50 - 75	Ceramic plunger / bronze bushing
	Packing D 50 - 80	Ceramik plunger / packing
501	Packing	Ceramik plunger / packing

D = Piston/Plunger dia. [mm]  
n1 = Motor/Engine r.p.m. [1/min]  
n2 = Crankshaft r.p.m. [1/min]

\*\* The dynamic high pressure sealing extends the advantages of the labyrinth design with further increased efficiency.

**HAMMELMANN®**