

# HDP 196

## Sewer cleaning pump



### Compact design

- Optimum space utilisation
- Light weight
- Integral reduction gear

### Easy servicing

- A single design for the suction and discharge valves
- Reversible valves and valve seats
- Service access via individual cover plates.
- Easy maintenance possible without removal of suction and pressure lines

### Environmentally friendly

- Quiet drive end due to twin helical gears
- Piston rods hermetically sealed by the NBR bellows, no oil leakage

### Adaptability provides installation options

- Reversible pump head
- Central or side suction connection
- Discharge connections on both sides
- Can operate at higher inclinations

### Drive end

- Hammelmann standard industrial drive end specifically designed for continuous duty
- Pressurised oil lubrication system
- High quality spheroidal cast iron housing
- Clockwise or anticlockwise rotation

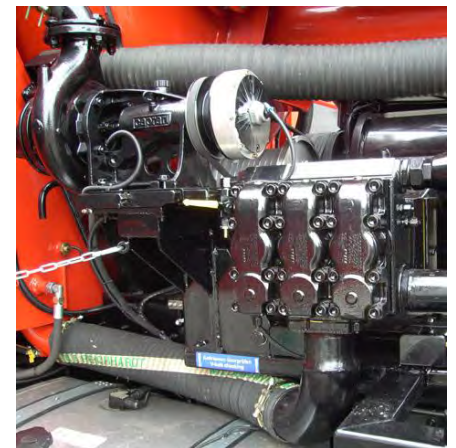

### Water end: suitable for recycled water

Less wear due to :-

- High grade solid ceramic plungers
- Wear resistant valve seats
- Low flow velocity over suction and discharge valves
- Packing seal sets within rust resistant stainless steel sleeves
- Slow plunger speed

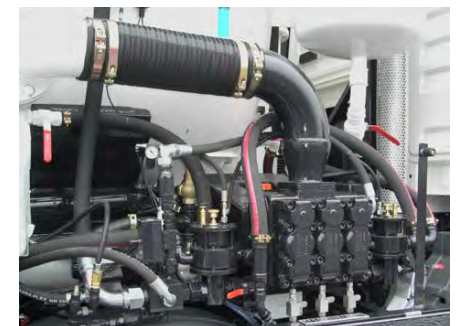

## Technical data HDP 196

- Rod force: 90 kN
- Stroke: 75 mm
- Mean piston speed at  $n_2$   
460 1/min = 1,15 m/sec  
550 1/min = 1,37 m/sec

[l/min]	Pressure [bar]	Power required [kW]	Piston Ø	$n_1$ [r.p.m.]	$n_2$ [r.p.m.]
386	210	150	70	1500/1800	460
460	210	180	70	1800/2150	550
440	185	150	75	1500/1800	460
530	185	180	75	1800/2150	550
505	160	150	80	1500/1800	460
605	160	180	80	1800/2150	550

## Technical details

Design	Horizontal, vertical, 3 cylinder
Plungers	Solid ceramic
Plunger sealing	Packings
Crank section sealing	Bellows
Valves	With ancillary sealing for recycled water
Valves, special feature	Reversible
Crank section lubrication	Pressurised circulating
Crankshaft bearings	2 x roller
Drive shaft	right or left

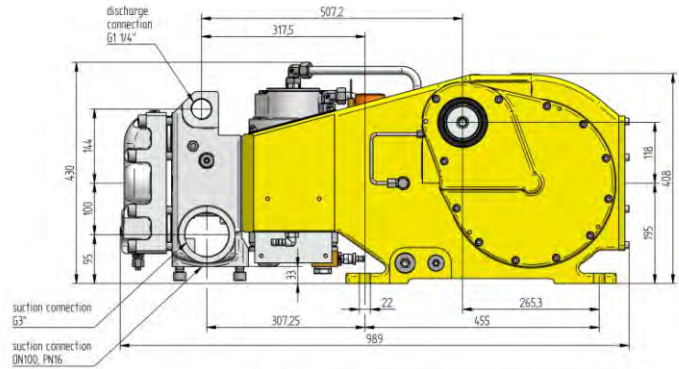

## Installation data

Weight incl. lub. oil	Approx. 580 kg
Mounting hole pattern	
HDP 196 horizontal	455 x 328 mm
HDP 196 vertical	426 x 360 mm
Drive shaft	65 mm dia. x 100 mm
Shaft key	DIN 6885 – A
Permissible lateral force	16 kN
Discharge connection	1 1/4" female
Suction connection	100 mm i/d, PN6 DIN 2631, 2 x 3"

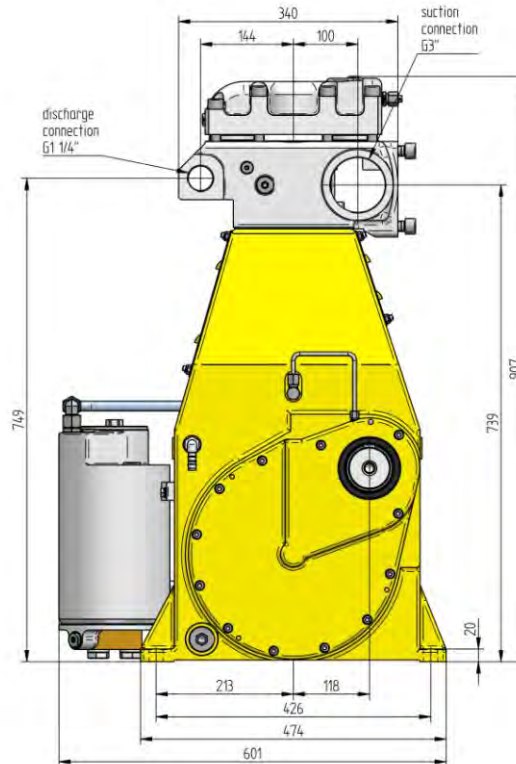
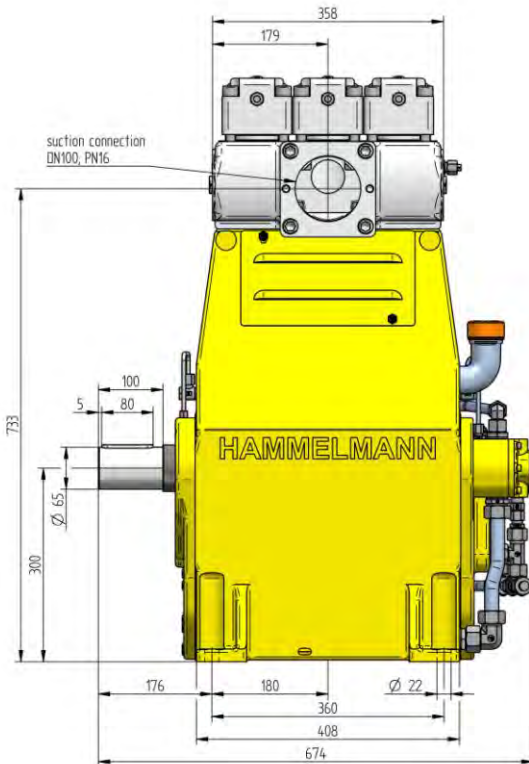
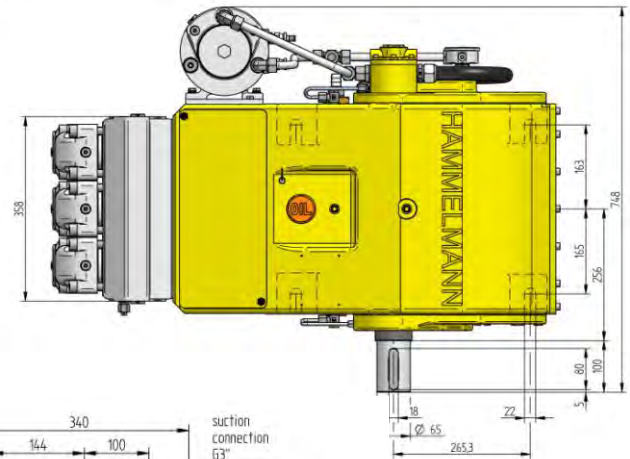

Horizontal design



Vertical design