

HAMPRO® 300 Process plunger pump

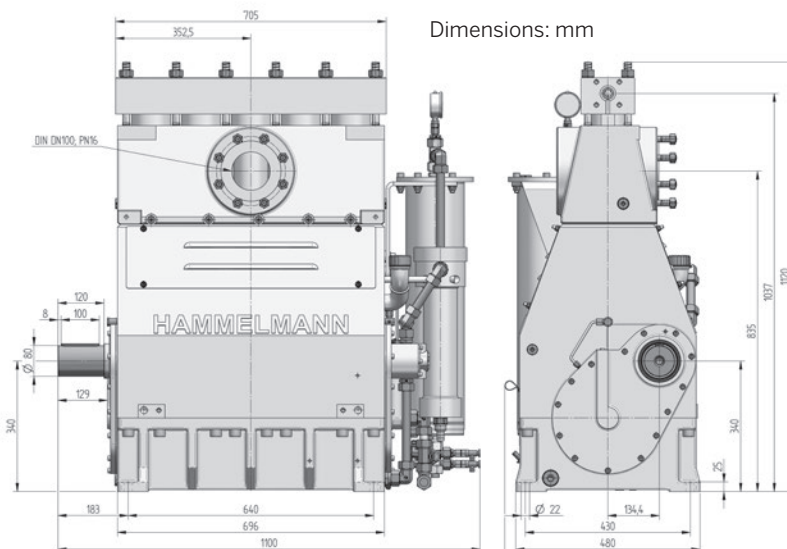

Hammelmann process pumps are built to operate at the continuous maximum duty stated in the performance parameters. Just compare the crankshaft speed, average plunger speed, plunger diameter and power rating.

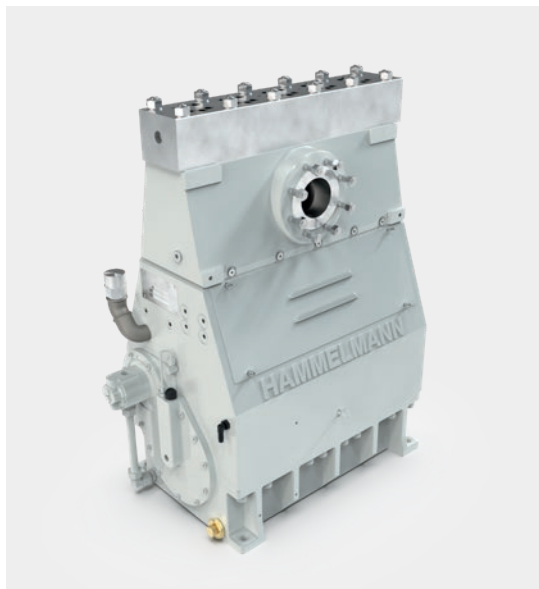

Quality and reliability

- Crank section calculation by 'Finite element method' ensures long working life under continuous load
- Stainless steel pump head free of alternating stress
- Integral speed reduction gear
- Pressurised oil lubrication system with oil cooler/filter
- Bellows form hermetic seal between the suction chamber and crank section
- Large selection of materials available for different fluids
- Minimum crankshaft speed with external oilpump 32 r.p.m.

Features

- Power ratings up to 300 kW
- Vertical 5 cylinder design

Technical details HAMPRO® 300

Operating pressure	Flow rate
up to 3200 bar	up to 64 m ³ /h
Design	Weight
Vertical 5 cylinder design	~ 1070 kg

Weight and dimensions refer to the pump only, without accessories. Detailed dimensional drawings and weights on request.

The bellow system is gastight.



Zero Emission



TA-Luft, (Clean Air) certified to VDI 2440

In the Zero Emission design the pumped fluid is hermetically sealed within the pump preventing leakage to atmosphere during operation.

Technical data, series HAMPRO® 300: Performance parameters (standard design)

HAM PRO®	Q** [l/min]	Q** [m³/h]	Required power rating [kW]				D [mm]	r.p.m.	
			110	160	200	300		n1	n2
			Operating pressure [bar]						
304	21	1,26	2350	3200			15	1216/1460	*400
	26	1,56	1900	2750	3200			1500/1800	493
	30	1,80	1600	2300	2900			1800/2150	591
	29	1,7	1700	2500	3150		17,5	1216/1460	*400
	39	2,3	1350	1950	2500			1500/1800	493
	47	2,8	1150	1650	2300	3200		1800/2150	591
	40	2,4	1300	1900	2400		20	1216/1460	*400
	51	3,1	1050	1500	1900	2800		1500/1800	493
62	3,7	900	1300	1600	2450	1800/2150		591	

303	65	3,9	850	1230	1540		25	1216/1460	*400
	86	5,2	670	970	1220	1800		1500/1800	493
	101	6,1	560	810	1020	1600		1800/2150	591
	84	5,0	670	980	1230		28	1216/1460	*400
	107	6,4	530	780	970	1430		1500/1800	493
	126	7,6	450	650	810	1300		1800/2150	591

302	97	5,8	590	860	1070		30	1216/1460	*400
	122	7,3	460	670	840	1240		1500/1800	493
	145	8,7	390	570	710	1100		1800/2150	591
	112	6,7	510	750	940		32	1216/1460	*400
	139	8,3	410	590	740	1090		1500/1800	493
	166	10,0	340	500	620	980		1800/2150	591
	135	8,1	430	630	780		35	1216/1460	*400
	167	10,0	340	500	620	910		1500/1800	493
	200	12,0	290	420	520	800		1800/2150	591
	178	10,7	330	480	600		40	1216/1460	*400
	221	13,3	260	380	470	700		1500/1800	493
	264	15,8	220	320	400	620		1800/2150	591
	227	13,6	260	380	470		45	1216/1460	*400
	282	16,9	210	300	380	550		1500/1800	493
	337	20,2	170	250	310	480		1800/2150	591
	283	17,0	210	300	380		50	1216/1460	*400
	352	21,1	170	240	300	450		1500/1800	493
	421	25,3	140	200	250	380		1800/2150	591
	343	20,6	175	250	310		55	1216/1460	*400
	426	25,6	140	200	250	370		1500/1800	493
	509	30,5	120	170	210	320		1800/2150	591
	410	24,6	145	210	260		60	1216/1460	*400
	502	30,1	120	170	210	310		1500/1800	493
	600	36,0	100	140	180	270		1800/2150	591
	482	29	125	180	220		65	1216/1460	*400
	589	35	100	140	180	260		1500/1800	493
	709	43	80	120	150	230		1800/2150	591
	560	34	105	155	195		70	1216/1460	*400
	683	41	90	120	160	230		1500/1800	493
	818	49	70	100	130	200		1800/2150	591
733	44	80	120	150		80	1216/1460	*400	
892	54	65	95	120	170		1500/1800	493	
1069	64	55	80	100	150		1800/2150	591	

Data

- Rod force: 88 kN
- Stroke: 75 mm
- Mean plunger speed at n2:

400 r.p.m. = 1,00 m/sec

493 r.p.m. = 1,23 m/sec

591 r.p.m. = 1,48 m/sec

Certificates

- Machine directive 2006/42/EG
- ATEX 2014/34/EG
- API 674
- TA-Luft (Clean Air)
- NORSOK M501
- NORSOK M650
- NACE MR0175

Standards

- DIN EN ISO 9001
- DIN EN ISO 14001
- DIN EN ISO 50001
- BS OHSAS 18001
- ASME-U
- Achilles
- EAC



Hammelmann plunger pumps convert 93 to 98 % of the shaft power to hydraulic energy.

**Data refer to the medium water (compressibility considered)

* Speed limit for continuous service according to API 674 – 6.3.1

D = Plunger diameter

n1 = Motor/Engine r.p.m.

n2 = Crankshaft r.p.m.