



**DERC ROTOCAR NOZZLES & ACCESSORIES**



**DERC ROTOCAR, EASY OPERATION**



**DERC ROTOCAR, ALWAYS AT A SAFE DISTANCE**



**DERC ROTOCAR HOSE GUIDE**



## DERC Rotocar Cleaning System

- + ROTATES HOSE BY AIR MOTOR
- + PUSHING AND PULLING MADE EASY
- + FOR COMPLEX, BENDED PIPE LINES
- + MAX. WORKING PRESSURE 3000 BAR

**MADE BY  
DERC**

DERC SALOTECH – ORIGINAL EQUIPMENT MANUFACTURER AND SUPPLIER OF INNOVATIVE HIGH PRESSURE WATER JETTING SOLUTIONS, AUTOMATED EQUIPMENT AND ACCESSORIES. WE PROVIDE STATE OF THE ART KNOWLEDGE AND SERVICES.

## Removal of difficult scales and incrustations on the inside of tubes and pipelines



The DERC RotoCar Cleaning System is developed to remove difficult scales and incrustations on the inside of tubes or pipelines in a very fast and highly efficient way, with extremely high safety standards for the operator.

The DERC RotoCar unit rotates a rubber high pressure hose. The rotation is done by an air motor. The “feed mechanism” will feed or pull the hose automatically in or out of the tube. The speed of the high pressure hose is manually adjustable for optimal cleaning results with different applications.



FAST AND EFFECTIVE CLEANING WITH HIGH OPERATOR SAFETY

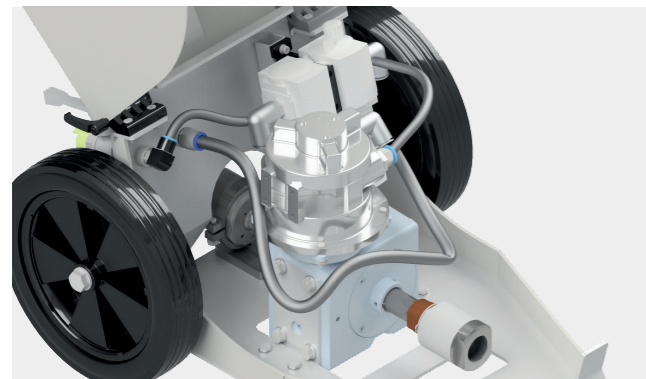

### ROTATE, PUSH & PULL

The RotoCar combines a fast and effective way of cleaning with high operator safety. The RotoCar rotates a high pressure hose by means of a swivel, gearbox and air engine. The rotating hose runs through the feeder unit which pushes or pulls the high pressure hose in or out of the tube. The RotoCar is equipped with a slip coupling which ensures that the high pressure hose can only rotate while it is on pressure.

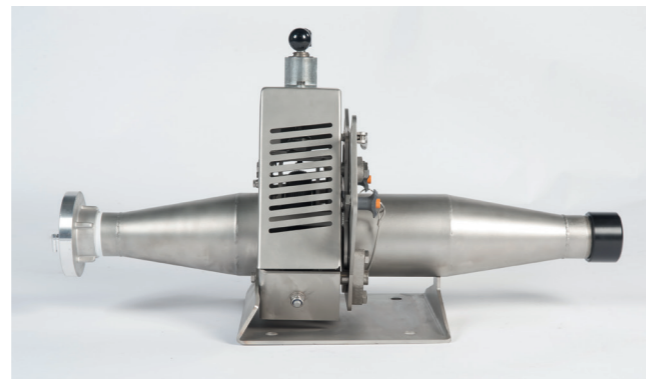

### FAST AND HIGHLY EFFECTIVE

The speed of the high pressure hose is manually adjustable for optimal cleaning result with different applications. To insert the hose in the middle of the tube an adjustable clamping device is mounted on the front of the tube or pipe. To prevent damage to the rotating hose there is a 2" stainless steel flexible tube mounted between the clamp device and the feed mechanism.



### CLEANS COMPLEX, BENDED PIPES

The rotating hose in combination with our special nozzle range ensures a perfect cleaning effect and is suitable for cleaning the most complex, bended and longest pipe line constructions. The maximum working pressure is 1500 bar at a maximum flow of 380 litre per minute.



### SPECIFICATIONS

- + Rotating speed: adjustable from 20 till 300 rpm
- + Length protecting hose: 3 m (10 ft)
- + Material: all stainless steel
- + Weight: approximate 65 kg
- + Hose connection: M24 x 1.5 DKOS male, M36 x 2 DKOS male (inlet and outlet) or 9/16" HP