

Hammelmann Injection Pumps

INNOVATION THROUGH EXPERIENCE

CALDER



Methanol

LDHI

Glycol

Asphaltene Inhibitor

Paraffin Inhibitor

Corrosion Inhibitor

Scale Inhibitor

Calder offer a wide range of high pressure pump packages incorporating Hammelmann pumps for the chemical, oil and gas industries. Visit our website.

www.calderltd.com

HAMMELMANN®

Exclusive sealing system

Labyrinth seal

This seal design which is absolutely unique to Hammelmann enables safe, reliable, continuous duty operation at pressures up to 3800 bar.

The high pressure seal is formed within the minute cylindrical gap between the plunger and the labyrinth insert. The medium pressure is continuously reduced along the sealing surface. A minimum amount of high pressure leakage serving as lubricant is returned to the pump suction chamber.

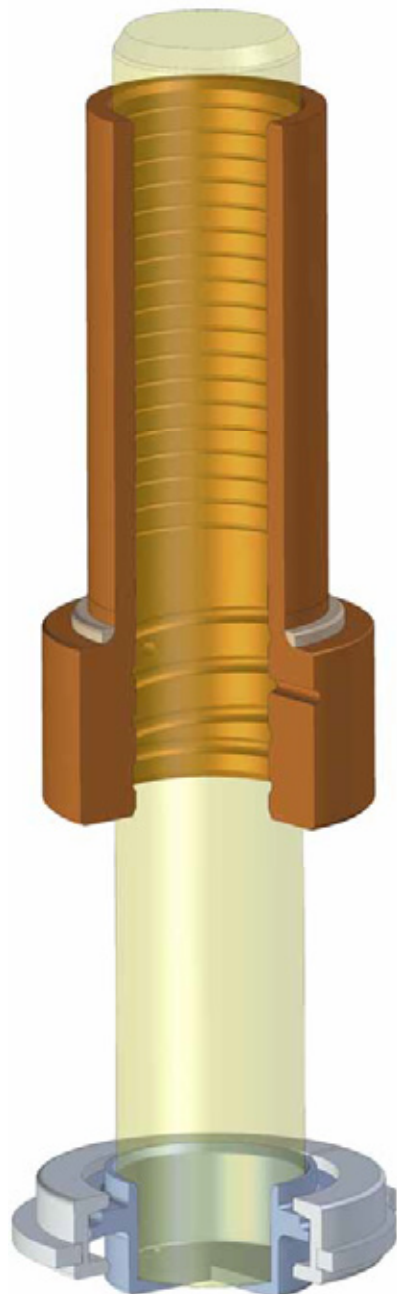
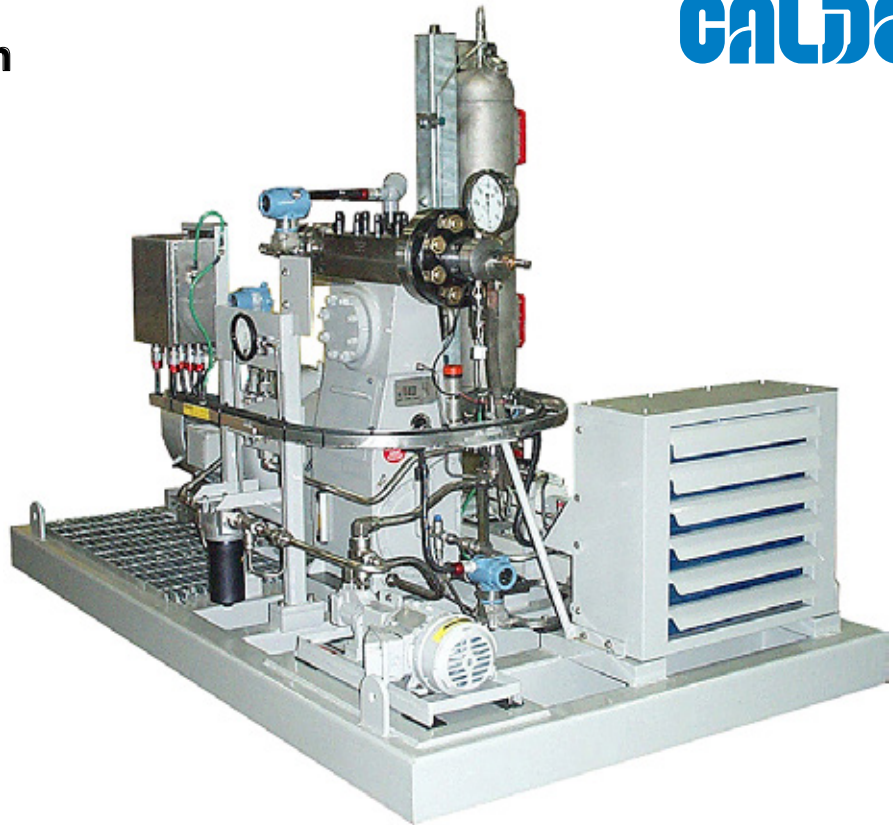

The plunger connection to the power end is self centering thereby drastically reducing sideways forces. This design ensures that there is virtually no contact between the plunger and the labyrinth insert resulting in extremely low component wear.

When the pump unit is shut down the medium remains in the cylindrical gap so that a re-start, even after an extended shut down period is assured.

Wear at the high pressure seal components does not lead to an abrupt breakdown of the pump but rather a gradual decrease in the flow rate. If the pump is driven in a control loop the r.p.m. of the driver will increase in direct proportion to component wear.

We manufacture extremely compact Triplex and Quintuplex pump units for injection of Methanol, LDHI, Glycol and a range of inhibitors.

Hammelmann high pressure pump units in the pressure range up to 15,000 psi (1035 bar) have developed into the standard choice for offshore methanol injection applications with a reputation for extreme reliability and minimal maintenance requirements.

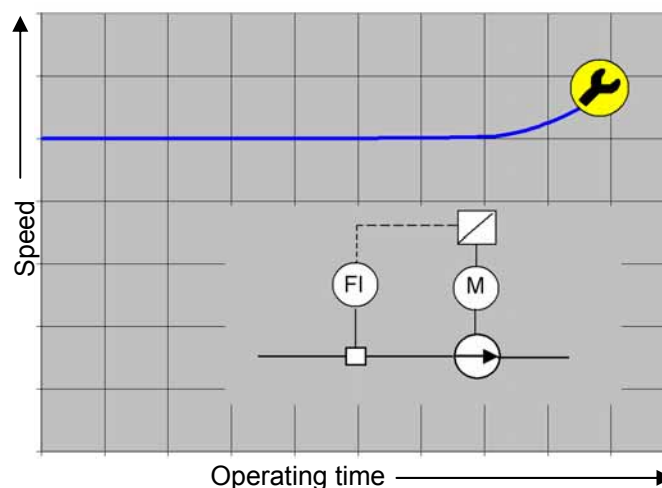

The running speed of the pump is a direct indicator of the extent of wear. This enables long term planning of maintenance intervals and targeting of specific servicing tasks.

Compact construction

Hammelmann pumps produce maximum performance from a minimal footprint which is the result of combining a compact integral speed reduction gear end with the concept of a vertical configuration.

The vertical configuration channels oscillating forces directly downwards into the base structure. Unwanted lateral oscillations as produced by horizontal pumps do not occur.

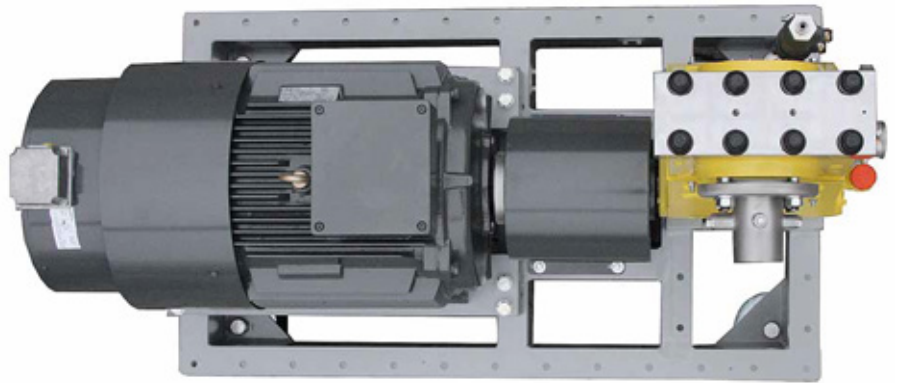

The integral speed reducer with twin helical gears arranged in a herring bone configuration ensures smooth running and even power transmission without axially loading the bearings.

A selection of gear ratios is available to allow the optimal choice of driver. The compact construction eliminates the need for an external gear box and prevents rotary oscillation. Mechanical efficiency is in excess of 95%.



Extensive performance range

With both Triplex and Quintuplex pumps available we can supply a very extensive range of flow rates and operating pressures.

Power ratings
up to 1000 HP
up to 750 kW

Flow rates
up to 600 gpm
up to 2500 l/min

Operating pressures
up to 55,000 psi
up to 3800 bar

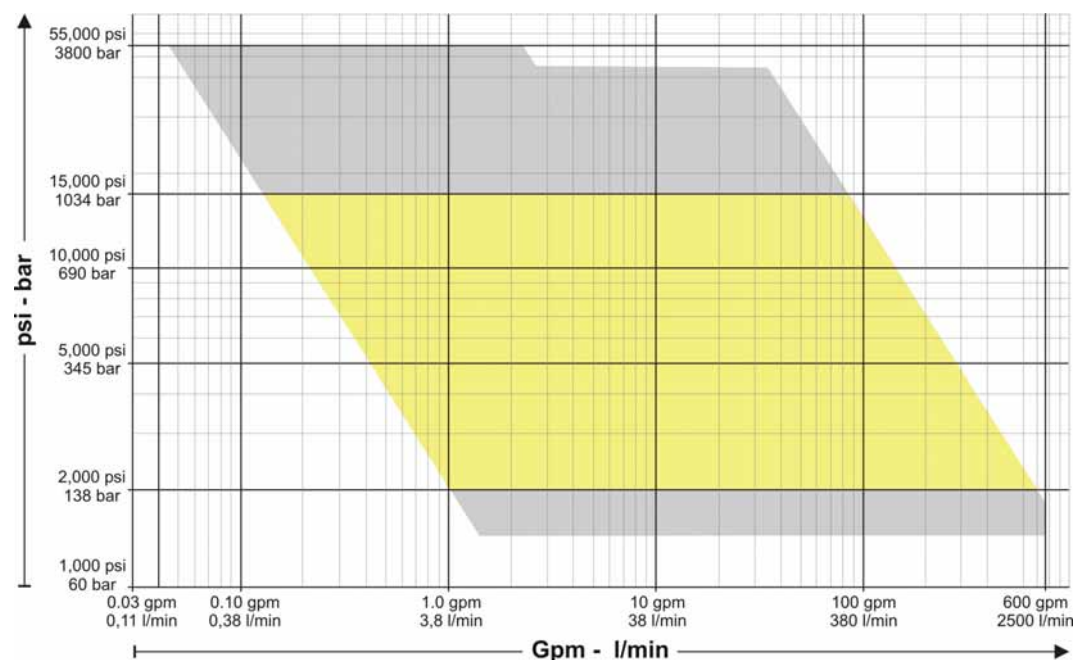

Hammelmann pump range

Injection pumps

Industrial pumps, series 2

Features

Series 2 pumps employ the same precision engineered, field proven components as Hammelmann standard production pumps. They are extremely compact with low maintenance costs and high operational efficiency.

Plunger speed

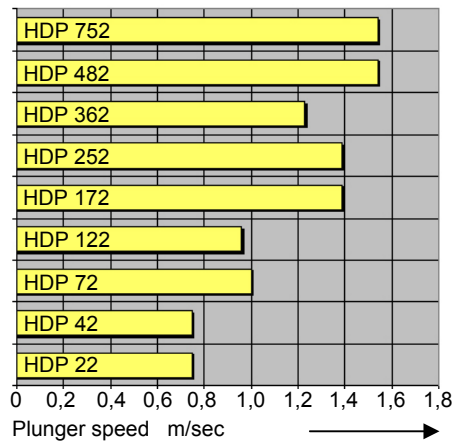

Moderate plunger speeds result in low plunger and sealing element wear characteristics.

Units

Our high pressure pump units can be supplied with electric motor, a choice of controls, safety valves and suction side/discharge side pulsation dampers.

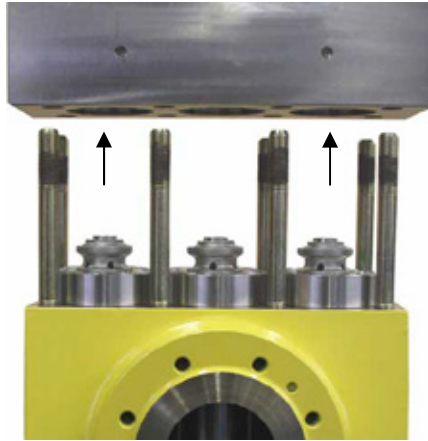

Maintenance

Pump maintenance is carried out from above. Once the pump head is removed you have complete, uncomplicated access to all high pressure components.

Pump head

The total pressurised fluid product of the individual cylinders collects within a single high pressure discharge bore within the pump head valve block. The coaxial valve arrangement eliminates alternating stress within the valve block.

Suction chamber

The process fluid enters the pump via the suction chamber. This totally encloses the high pressure components in a protective barrier and prevents emission of medium to atmosphere.

Seal monitoring

The condition of the low pressure seals may be monitored by installing an optional seal monitoring system.



Valves

The suction valve (below) is a disc ring design incorporating a one piece suction and discharge valve seat.

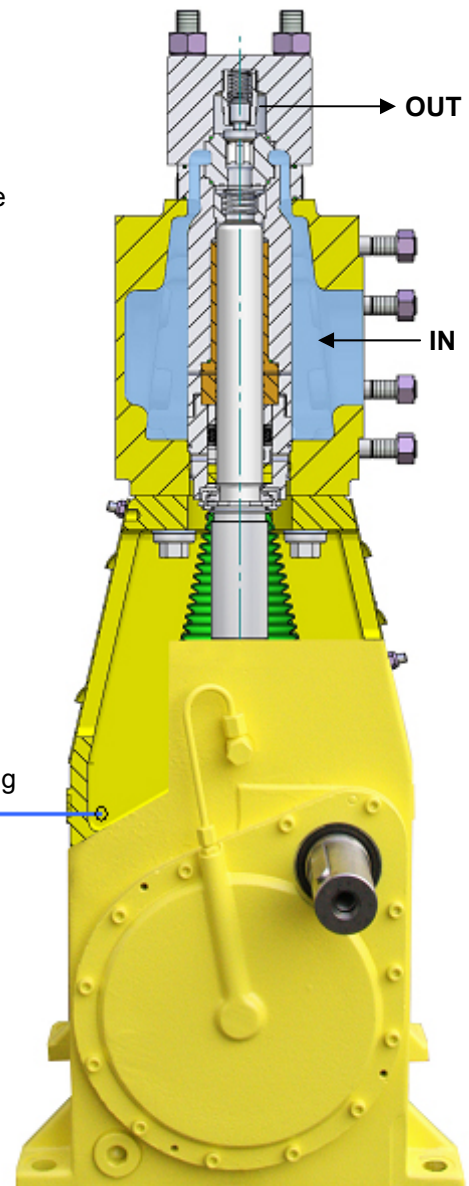

Pos.	Part name	Pos.	Part name
1	Discharge valve	8	Low pressure seal pack
2	Valve housing	9	Bellow
3	Suction valve	10	Crosshead
4	Suction chamber	11	Connection rod
5	Sleeve	12	Gear HDP 22/42: belt drive
6	Labyrinth insert	13	Crank shaft
7	Plunger	14	Crank section housing

Wetted parts materials *

	Standard	Option
Plunger	Ceramic	-
Labyrinth insert	Bronze	-
Valve housing	17% Chromium steel	22% Duplex steel
Seals	NBR / Polyamide	FKM / PEEK
Suction chamber	Bronze	18 – 10 Chromium Nickel steel

* Right reserved to make technical modifications

Recommendations and standards

Machine directive 2006/42/EC
ATEX 94/9/EC
API 674 (with exceptions)

	690 bar	15,000 psi	1035 bar	Crank speed
D 15		D 12		750 rpm
	10 l/min	1.6 gpm	6 l/min	
D 26		D 20		750 rpm
	31 l/min	4.7 gpm	18 l/min	
D 26		D 22		750 rpm
	42 l/min	7.4 gpm	28 l/min	
D 35		D 30		530 rpm
	74 l/min	13 gpm	51 l/min	
D 35		D 30		555 rpm
	108 l/min	20 gpm	75 l/min	
D 35		D 30		555 rpm
	181 l/min	32 gpm	124 l/min	
D 60		D 45		490 rpm
	282 l/min	38 gpm	146 l/min	
D 60		D 45		465 rpm
	349 l/min	47 gpm	181 l/min	
D 60		D 45		465 rpm
	603 l/min	79 gpm	302 l/min	

Process pumps, series 5

Features

Series 5 pumps are built to the highest standards of safety and reliability. We can supply components from a wide range of materials to suit the pumped medium.

Our latest variation of this pump series is the **Zero emission** where the pumped fluid is hermetically sealed within the pump, preventing leakage to atmosphere during operation.

Plunger speed

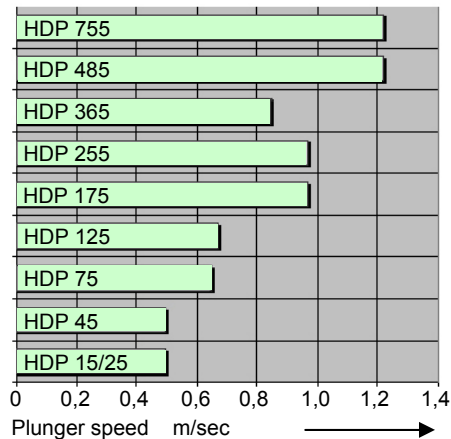

The series 5 pumps are conservatively rated for power with low plunger speeds ensuring limited wear of plungers and sealing elements.

Units

Your complete pump unit can be outfitted with suction and/or discharge pulsation dampers dimensioned, manufactured, tested and certified to your specification.



Bellows system

The bellows are the hermetic seals for the power end to prevent the intrusion of fluid or gas. They are available in FKM, H-NBR and PTFE.



TA-Luft (Clean Air) certified to VDI 2440

Valves

To ensure that the pump construction is appropriate for the pumped medium we have a number of alternative valve designs available. In the example shown below the suction and discharge valves are conical. The suction and discharge valve seats are combined in one component.

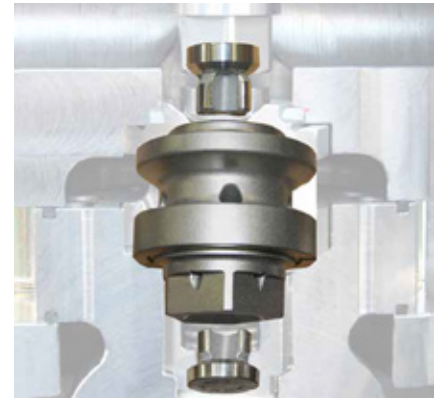

Gas tight design

The intermediate chamber of the pump can be outfitted with gas tight covers which provide a seal to atmosphere. The chamber is then charged with inert gas.

This design ensures that no fluids, vapours or gases can escape to atmosphere via a worn plunger seal.

- 1 = Priming valve
- 2 = Safety valve
- 3 = Pressure regulating valve

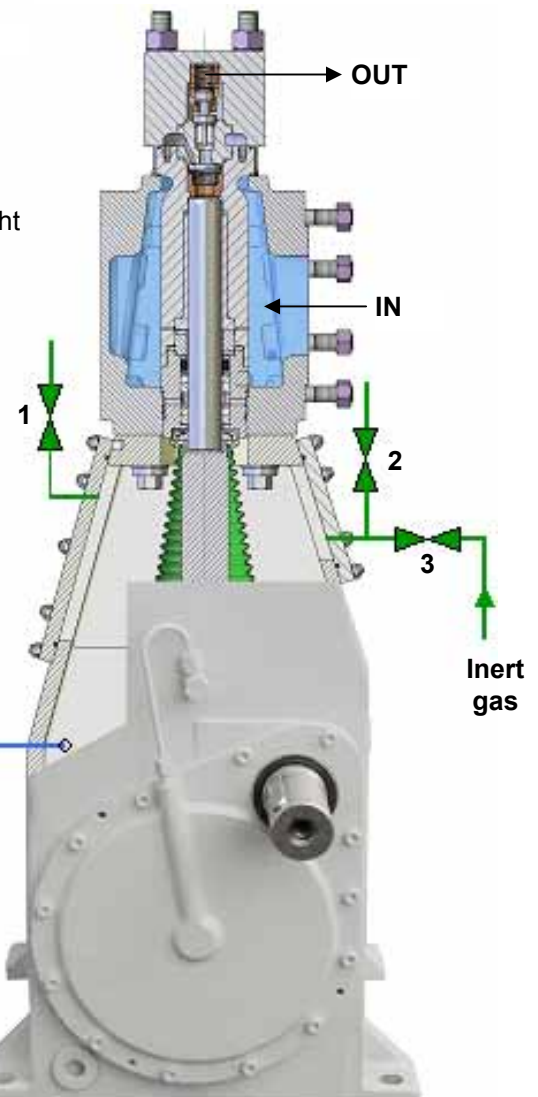

LI Seal monitoring system

Technical data, series 5

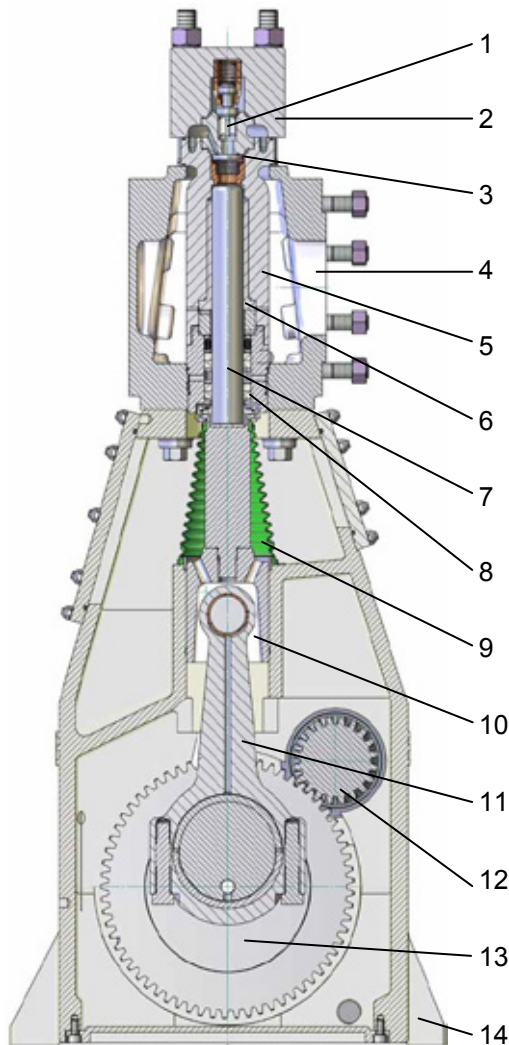

Pos.	Part name	Pos.	Part name
1	Discharge valve	8	Low pressure seal pack
2	Valve housing	9	Bellows
3	Suction valve	10	Crosshead
4	Suction chamber	11	Connection rod
5	Sleeve	12	Gear HDP 25/45: belt drive
6	Labyrinth insert	13	Crank shaft
7	Plunger	14	Crank section housing

Wetted parts materials *

	Standard	Option
Plunger	Ceramic	Tungsten carbide
Labyrinth insert	Bronze	Tungsten carbide
Valve housing	22% Duplex steel	25% Super duplex steel
Seals	NBR / Polyamide	FFKM / PEEK
Suction chamber	18–10 Chromium Nickel steel	25% Super duplex steel

* Right reserved to make technical modifications

Recommendations and standards

Machine directive 2006/42/EC

ATEX 94/9/EC

API 674 (with exceptions)

Other customer specified standards, i.e.

GOST-U

GOST-TR

NORSOK M501

NORSOK M650

NACE MR0175

ROSTEKHNADSOR

Performance data, series 5 (Selection)

Pump model	5,000 psi	345 bar	10,000 psi	690 bar	15,000 psi	1035 bar	Crank speed
	D 17,5		D 17,5 *		D 12		
HDP 15 / HDP 25*	2.6 gpm	10 l/min	2.5 gpm	9.5 l/min	1.1 gpm	14.3 l/min	420 rpm
HDP 45	D 35		D 26		D 20		500 rpm
	10 gpm	40 l/min	5 gpm	20 l/min	3 gpm	12 l/min	
HDP 75	D 35		D 26		D 22		490 rpm
	13 gpm	52 l/min	7 gpm	28 l/min	5 gpm	19 l/min	
HDP 125	D 55		D 35		D 30		365 rpm
	35 gpm	133 l/min	13 gpm	51 l/min	9 gpm	35 l/min	
HDP 175	D 50		D 35		D 30		385 rpm
	42 gpm	160 l/min	19 gpm	74 l/min	13 gpm	52 l/min	
HDP 255	D 50		D 35		D 30		390 rpm
	71 gpm	270 l/min	33 gpm	126 l/min	23 gpm	87 l/min	
HDP 365	D 80		D 60		D 45		340 rpm
	95 gpm	363 l/min	51 gpm	194 l/min	26 gpm	101 l/min	
HDP 485	D 80		D 60		D 45		365 rpm
	137 gpm	520 l/min	73 gpm	279 l/min	38 gpm	145 l/min	
HDP 755	D 80		D 60		D 45		365 rpm
	229 gpm	867 l/min	127 gpm	483 l/min	63 gpm	242 l/min	

D = Piston dia [mm]

The compact design of Calder pump packages incorporating Hammelmann pumps, offers a space saving advantage for installation on offshore platforms and FPSO's. They are increasingly specified as the pumps of choice for offshore installations.

Round the clock operation

- | | |
|-----------------|-----------------|
| Asgard | Kristin |
| Agbami | Longhorn |
| Aker 1-6 | Mad Dog |
| Allegheny | Magnolia |
| Anna Platform | Marco Polo |
| Atlantis | Max-Stena-Drill |
| Auger | Mobile Rig |
| Auger Apit | Morvin Asgard |
| Baton Rouge | Neptune |
| Black Widow | Nile |
| Brazil | Noonan |
| Brutus/Glider | Norse Marchand |
| BS4 | Panama City |
| Cabida Block | Pegasus |
| Canyon Express | Perdido |
| Conger Salsa | Petrorig |
| Demos | Producer |
| Forvie | Scarebo |
| Garden Banks | Schahin |
| Garnet | Sevan |
| Gjoa Semi | S. Timbalier |
| Groupo R | Stafford B & C |
| Hickory | Tahiti |
| Holstein | Talisman |
| Horn Mountain | Tanzanite |
| Houma | Tarantula |
| Indep. Hub 3 | TMT 1 |
| Independence | Tweedsmuir |
| Janice | Typhon |
| K2 Green Canyon | Ursa-Princess |
| K-Fels | Valifornia |
| Kikeh-Gusto | Vega |
| King Kong | West Edrill |
| Kings Peek | |



HDP 115 units for methanol duty
Op. pressure 15,000 psi – 1035 bar
Flow rate 1.5 gpm – 6 l/min



HDP 175 units for methanol duty
Op. pressure 5,300 psi – 370 bar
Flow rate 46 gpm – 176 l/min



HDP 72 unit for methanol duty
Op. pressure 12,000 psi – 830 bar
Flow rate 6 gpm – 24 l/min

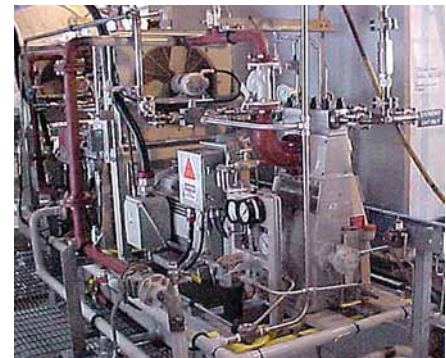

HDP 122 unit for LDHI duty
Op. pressure 15,000 psi – 1035 bar
Flow rate 7 gpm – 28 l/min



HDP 555 pump unit for glycol and methanol duty
Op. pressure 10,700 psi – 740 bar, Flow rate 87 gpm – 333 l/min



Calder Ltd.

Prescott Drive
Warndon
Worcester
WR4 9NE
United Kingdom

web: www.calderltd.com
email: sales@calder.co.uk
Phone: + 44 (0) 1905 751790

HAMMELMANN[®]